



2017-2018 PRODUCTS CATALOG



DAIWA INDUSTRIES LTD.

3 Reasons Why Customers Choose Us

**MADE IN
JAPAN**

Guarantee high quality and reliability through design, manufacturing and inspection - all process done in Japan.

For 220V/240V

3 Main speciality for quality

aiwa



Design quality

Accumulated “knowledge” and “skills” will make the best quality. Pursuit of usage and serviceability. We repeat design verification to sustain and improve Japan Quality to the highest.

Manufacturing quality

We aim for the highest quality. We continue to produce best quality products from our manufacturing by harmonizing skilled specialists we call “TAKUMI” with high performance manufacturing equipments.



Inspection quality

We inspect our products from customer’s viewpoint. We check every single product to make sure not to send defective items to customers.

Contents

	2	Product Information/Product list
Upright refrigerator/freezer	3-4	Details of upright refrigerator/freezer
	5-6	Refrigerator
	6-8	Freezer
Undercounter	9-10	Details of undercounter
	11-12	Refrigerator
	12-13	Freezer
	14	Counter type showcase
	15-16	Inverter controlled counter showcase Ecozo-kun
	17	Inverter controlled refrigerator/freezer Ecozo-kun
	18	Inverter controlled electronic freshness retention refrigerator Sendo-kun
	19	Inverter controlled Automatic-sliding door refrigerator Auto-kun
	20	Inverter controlled sliding door refrigerator Ecozo-kun
	21-22	Product list(Inverter Controlled product)

Product information

Upright refrigerator/freezer		Undercounter	
DL R 12 8 A H		DK F 15 7 A H	
power supply	H:220V 50Hz	power supply	H:220V 50Hz
model	A: first model	model	A: first model
product depth(mm)	8 : 800 6 : 650	product depth(mm)	6 : 600 7 : 750
product width(mm)	06 : 600 07 : 750 09 : 900 12 : 1200 15 : 1500 18 : 1800	product width(mm)	09 : 880 12 : 1200 15 : 1500 18 : 1800
variety	R : refrigerator F : freezer	variety	R : refrigerator F : freezer
type	DL:Upright	type	DK:Undercounter

Product list

Upright refrigerator/freezer P.5~P.8

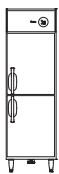
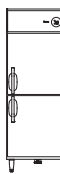
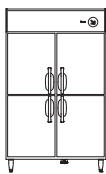
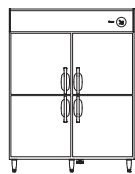
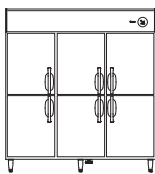
		600mm		750mm		1200mm		1500mm		1800mm	
Refrigerator Freezer	RC : -6°C to 12°C FC : -25°C to -7°C										
	Refrigerator	800mm P.5 DLR-068AH	P.5 DLR-078AH	P.5 DLR-128AH	P.6 DLR-158AH	P.6 DLR-188AH					
Freezer	Refrigerator	650mm P.5 DLR-066AH		P.5 DLR-126AH	P.6 DLR-156AH	P.6 DLR-186AH					
	Freezer	800mm P.6 DLF-068AH	P.7 DLF-078AH	P.7 DLF-128AH	P.7 DLF-158AH	P.8 DLF-188AH					
		650mm P.6 DLF-066AH		P.7 DLF-126AH	P.7 DLF-156AH	P.8 DLF-186AH					

Undercounter P.11~P.13

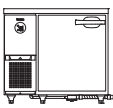
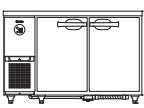
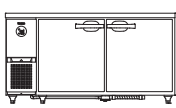
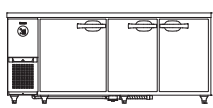
		880mm		1200mm		1500mm		1800mm	
Refrigerator Freezer	RC : -6°C to 12°C FC : -25°C to -7°C								
	Refrigerator	600mm P.11 DKR-096AH	P.11 DKR-126AH	P.11 DKR-156AH	P.12 DKR-186AH				
Freezer	Refrigerator	750mm P.11 DKR-097AH	P.11 DKR-127AH	P.11 DKR-157AH	P.12 DKR-187AH				
	Freezer	600mm P.12 DKF-096AH	P.12 DKF-126AH	P.13 DKF-156AH	P.13 DKF-186AH				
		750mm P.12 DKF-097AH	P.12 DKF-127AH	P.13 DKF-157AH	P.13 DKF-187AH				

RC:Refrigerating compartment
FC:Freezing compartment

Upright refrigerator/freezer



Satisfying Usability

A firm durability for professional users. High accurate temperature control by Micro-computer and also seeking after the appearance beauty.

Micro-computer Controlled & Digital Display

Adapted Micro-computer control method that can set the temperature in 1°C increments depending on food items. Filter alarm let you know when to clean it and a button to enforce defrost is available.



Passed 300,000 Times Open / Close Test

Strengthen the door by installing stainless steel hinges to endure frequent open / close movements.



Automatically Closed Door

The door will be closed automatically, so you don't have to worry about leaving it open. It will prevent inside temperature to go up.

Whole Body Foam Insulation Structure

CFC-free Thermal Insulator

Including the partition, the whole body foam insulated to strengthen and improve thermal insulation. Ozone depletion potential(ODP) is zero and CFC-free thermal insulator made with "cyclopentane" foaming leads to a eco-friendly product.



Stopper Rack to Prevent Overload

A stopper is installed on the rack to prevent overload which will allow cool air to flow smoothly inside the refrigerator and keep the compartment at a constant temperature.

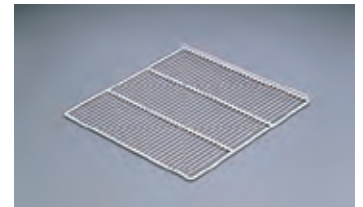

Thermal Insulated Door-back / Gasket

Improved door-back and gasket enhance thermal insulation performance.



Embedded Gasket

Easy to install due to the inlay type.



Easy Maintenance

We simplified maintenance to be able to use the refrigerator for a long time. Simple cleaning steps for everyday maintenance.

Clear Coat Stainless steel

Clear Coat Stainless steel is used for the doors and the front cover. Better water-repellency, oil-repellency allows you to clean stains from foods, fingerprints on the surface easily. Improved materials will make it even easier to keep your refrigerator clean.



Curved Edges Inside

Edges and corners are curved. Therefore it is easy to clean the edges.

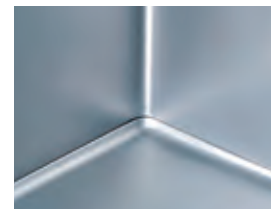

Large Drain Trap

A larger hose prevents clogging and makes it easy to clean. It also prevents bugs to come inside or leakage of cool air or odors.



Easy-grip Handles

Handles are designed for an easy gripping for open and close the door with a delicate design.

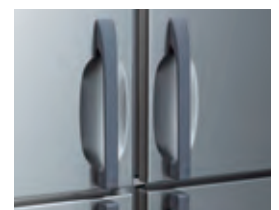

Flip-up the Front Panel

Flip-up front panel makes it easy to check and maintenance.



Air Filter

Air filter protect condenser from dusting. The filter is easy to depart for washing.



*Please clean it twice a month for a smooth running.

Attentive design, safety for customers

We support effective utilization of space through easy delivery various size and reversible doors. Our refrigerators fit to various kitchen layout.

Reverse Doors

You can freely set the door direction according to the installed location. (parts to reverse door are available as option)

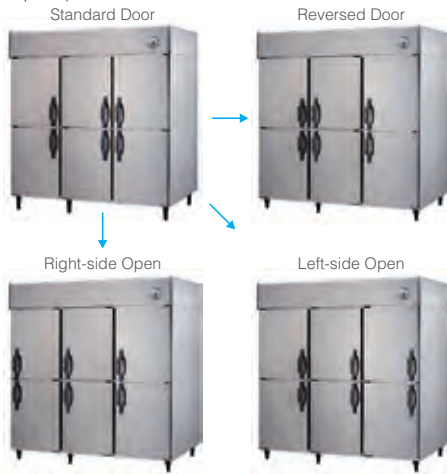

Machine unit separate type

For easy delivery of the products, machine units can be easily separated.



Resin Legs

Prevent stains and rust. Easy to adjust the high (30mm maximum adjustable)



Earth Leakage Breaker

Earth leakage breaker is equipped to strengthen the safety of customers.



Optional Parts

Please inquire us for delivery date and prices of optional parts as some of them are made to order.

Drainage Tank

Drainage tank store water from defrosting. You don't have to have sewage nearby to place the refrigerator.

*Please drain water every day.

Type	Parts code	Size (mm)			Capacity (ℓ)
		Width	Length	Height	
A	85001279	300	355+45 (Handle)	50	3
B	54350723	400	400+45 (Handle)	40	4
C	85001276	140	355+45 (Handle)	110	4
D	54350763	280	345	160	9
E	85001275	200	405+50 (Handle)	150	10

Key Option (made to order)

Key can be installed on horizontal pillar of upright type refrigerators.

*Please use a padlock on the market.

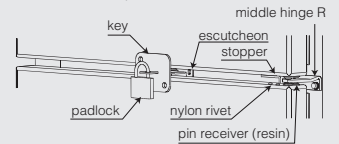

Drainage Automatic Evaporate Unit (made to order)

Water from defrosting will be stored on an evaporation plate and automatically evaporated. Plumbing work is not necessary. The unit is very useful for the place with no sewage system or difficult to do plumbing work.

*Please extend adjustable legs to over 100mm. Change adjustable legs when you cannot extend them over 100mm.



Model	Size (mm)			Power	Ability to Evaporate (cc/hour)
	Width	Length	Height		
JU220V	320	450	95	220V 1 φ 145W	120

Width **600 mm**

Width **750 mm**

Width **1200 mm**

DLR-068AH

- OUTSIDE DIMENSIONS : W600xD800xH1960mm
- WEIGHT : 85kg
- POWER SUPPLY : 1 Phase 220V, 50Hz



Non-Freon

EFFECTIVE CAPACITY(L)
486L

ELECTRIC CONSUMPTION	Cooling	227W
	Motor	200W
	Heater	304W
COMPRESSOR	Hermetic 200W	
REFRIGERANT	HFC R134a 125g	
DEFROST SYSTEM	Heater	
ACCESSORIES	SHELF	3 pcs
	BOTTOM SHELF	1 pc
	SHELF CLIP	12 pcs
	DRAINAGE PARTS	1 set

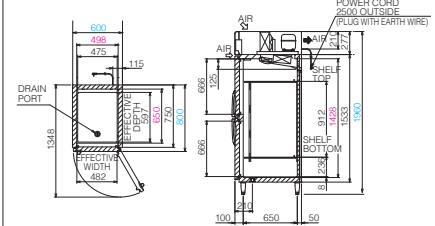

DLR-078AH

- OUTSIDE DIMENSIONS : W750xD800xH1960mm
- WEIGHT : 94kg
- POWER SUPPLY : 1 Phase 220V, 50Hz



Non-Freon

EFFECTIVE CAPACITY(L)
638L

ELECTRIC CONSUMPTION	Cooling	229W
	Motor	200W
	Heater	306W
COMPRESSOR	Hermetic 200W	
REFRIGERANT	HFC R134a 125g	
DEFROST SYSTEM	Heater	
ACCESSORIES	SHELF	3 pcs
	BOTTOM SHELF	1 pc
	SHELF CLIP	12 pcs
	DRAINAGE PARTS	1 set

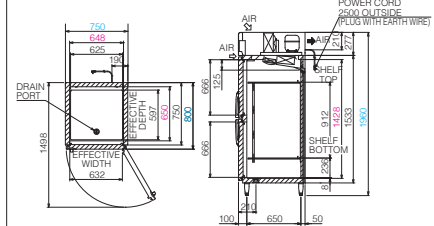

DLR-128AH

- OUTSIDE DIMENSIONS : W1200xD800xH1960mm
- WEIGHT : 135kg
- POWER SUPPLY : 1 Phase 220V, 50Hz



Non-Freon

EFFECTIVE CAPACITY(L)
1078L

ELECTRIC CONSUMPTION	Cooling	329W
	Motor	270W
	Heater	428W
COMPRESSOR	Hermetic 350W	
REFRIGERANT	HFC R404A 290g	
DEFROST SYSTEM	Heater	
ACCESSORIES	SHELF	6 pcs
	BOTTOM SHELF	2 pcs
	SHELF CLIP	24 pcs
	DRAINAGE PARTS	1 set

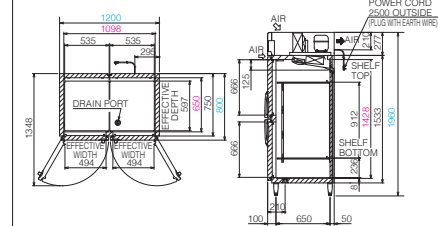

DLR-066AH

- OUTSIDE DIMENSIONS : W600xD650xH1960mm
- WEIGHT : 81kg
- POWER SUPPLY : 1 Phase 220V, 50Hz



Non-Freon

EFFECTIVE CAPACITY(L)
378L

ELECTRIC CONSUMPTION	Cooling	227W
	Motor	200W
	Heater	304W
COMPRESSOR	Hermetic 200W	
REFRIGERANT	HFC R134a 125g	
DEFROST SYSTEM	Heater	
ACCESSORIES	SHELF	3 pcs
	BOTTOM SHELF	1 pc
	SHELF CLIP	12 pcs
	DRAINAGE PARTS	1 set

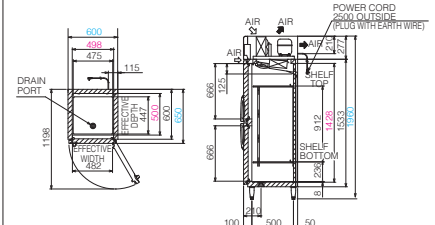

DLR-126AH

- OUTSIDE DIMENSIONS : W1200xD650xH1960mm
- WEIGHT : 125kg
- POWER SUPPLY : 1 Phase 220V, 50Hz



Non-Freon

EFFECTIVE CAPACITY(L)
840L

ELECTRIC CONSUMPTION	Cooling	329W
	Motor	270W
	Heater	428W
COMPRESSOR	Hermetic 350W	
REFRIGERANT	HFC R404A 290g	
DEFROST SYSTEM	Heater	
ACCESSORIES	SHELF	6 pcs
	BOTTOM SHELF	2 pcs
	SHELF CLIP	24 pcs
	DRAINAGE PARTS	1 set

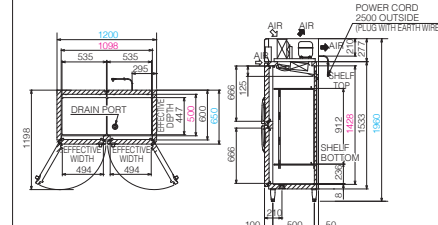

Depth
800 mm

Depth
650 mm

Refrigerator

Refrigerating compartment :
-6°C to 12°C



Freezer

Freezing compartment :
-25°C to -7°C

Up
Right

Width **1500 mm**

Width **1800 mm**

Width **600 mm**

DLR-158AH

- OUTSIDE DIMENSIONS : W1500xD800xH1960mm
- WEIGHT : 148kg
- POWER SUPPLY : 1 Phase 220V, 50Hz



Non-Freon

EFFECTIVE CAPACITY(L)
1383L

ELECTRIC CONSUMPTION	Cooling	334W
	Motor	270W
	Heater	433W
COMPRESSOR	Hermetic 350W	
REFRIGERANT	HFC R404A 290g	
DEFROST SYSTEM	Heater	
ACCESSORIES	SHELF	6 pcs
	BOTTOM SHELF	2 pcs
	SHELF CLIP	24 pcs
	DRAINAGE PARTS	1 set

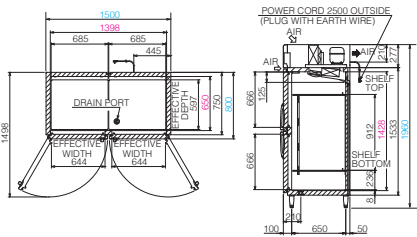

DLR-188AH

- OUTSIDE DIMENSIONS : W1800xD800xH1960mm
- WEIGHT : 176kg
- POWER SUPPLY : 1 Phase 220V, 50Hz



Non-Freon

EFFECTIVE CAPACITY(L)
1677L

ELECTRIC CONSUMPTION	Cooling	358W
	Motor	270W
	Heater	457W
COMPRESSOR	Hermetic 350W	
REFRIGERANT	HFC R404A 290g	
DEFROST SYSTEM	Heater	
ACCESSORIES	SHELF	9 pcs
	BOTTOM SHELF	3 pcs
	SHELF CLIP	36 pcs
	DRAINAGE PARTS	1 set

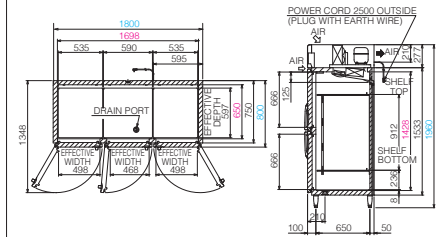

DLF-068AH

- OUTSIDE DIMENSIONS : W600xD800xH1960mm
- WEIGHT : 88kg
- POWER SUPPLY : 1 Phase 220V, 50Hz



Non-Freon

EFFECTIVE CAPACITY(L)
486L

ELECTRIC CONSUMPTION	Cooling	408W
	Motor	355W
	Heater	382W
COMPRESSOR	Hermetic 500W	
REFRIGERANT	HFC R404A 220g	
DEFROST SYSTEM	Heater	
ACCESSORIES	SHELF	3 pcs
	BOTTOM SHELF	1 pc
	SHELF CLIP	12 pcs
	DRAINAGE PARTS	1 set

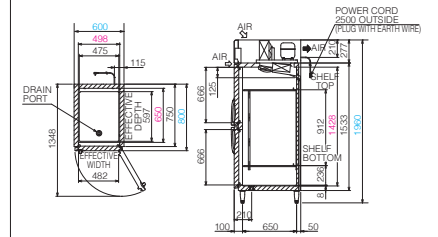

Depth
800 mm

DLR-156AH

- OUTSIDE DIMENSIONS : W1500xD650xH1960mm
- WEIGHT : 138kg
- POWER SUPPLY : 1 Phase 220V, 50Hz



Non-Freon

EFFECTIVE CAPACITY(L)
1075L

ELECTRIC CONSUMPTION	Cooling	334W
	Motor	270W
	Heater	433W
COMPRESSOR	Hermetic 350W	
REFRIGERANT	HFC R404A 290g	
DEFROST SYSTEM	Heater	
ACCESSORIES	SHELF	6 pcs
	BOTTOM SHELF	2 pcs
	SHELF CLIP	24 pcs
	DRAINAGE PARTS	1 set

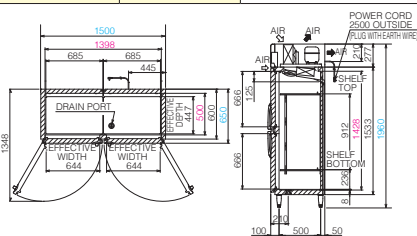

DLR-186AH

- OUTSIDE DIMENSIONS : W1800xD650xH1960mm
- WEIGHT : 166kg
- POWER SUPPLY : 1 Phase 220V, 50Hz



Non-Freon

EFFECTIVE CAPACITY(L)
1306L

ELECTRIC CONSUMPTION	Cooling	358W
	Motor	270W
	Heater	457W
COMPRESSOR	Hermetic 350W	
REFRIGERANT	HFC R404A 290g	
DEFROST SYSTEM	Heater	
ACCESSORIES	SHELF	9 pcs
	BOTTOM SHELF	3 pcs
	SHELF CLIP	36 pcs
	DRAINAGE PARTS	1 set

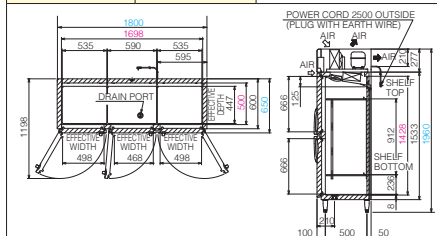

DLF-066AH

- OUTSIDE DIMENSIONS : W600xD650xH1960mm
- WEIGHT : 84kg
- POWER SUPPLY : 1 Phase 220V, 50Hz



Non-Freon

EFFECTIVE CAPACITY(L)
378L

ELECTRIC CONSUMPTION	Cooling	408W
	Motor	355W
	Heater	382W
COMPRESSOR	Hermetic 500W	
REFRIGERANT	HFC R404A 220g	
DEFROST SYSTEM	Heater	
ACCESSORIES	SHELF	3 pcs
	BOTTOM SHELF	1 pc
	SHELF CLIP	12 pcs
	DRAINAGE PARTS	1 set

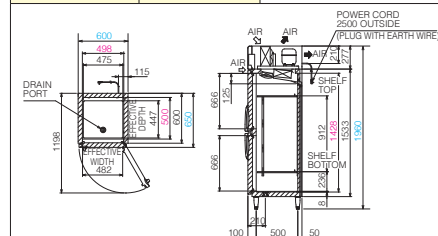

Depth
650 mm



Width **750 mm**

DLF-078AH

- OUTSIDE DIMENSIONS : W750xD800xH1960mm
- WEIGHT : 97kg
- POWER SUPPLY : 1 Phase 220V, 50Hz



Non-Freon

EFFECTIVE CAPACITY(L)
638L

ELECTRIC CONSUMPTION	Cooling	410W
	Moter	355W
	Heater	384W
COMPRESSOR	Hermetic 500W	
REFRIGERANT	HFC R404A 220g	
DEFROST SYSTEM	Heater	
ACCESSORIES	SHELF	3 pcs
	BOTTOM SHELF	1 pc
	SHELF CLIP	12 pcs
	DRAINAGE PARTS	1 set

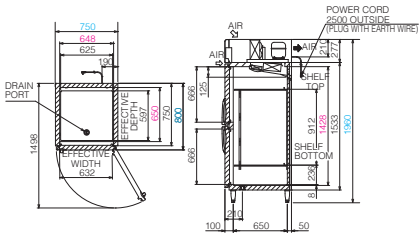

Width **1200 mm**

DLF-128AH

- OUTSIDE DIMENSIONS : W1200xD800xH1960mm
- WEIGHT : 140kg
- POWER SUPPLY : 1 Phase 220V, 50Hz



Non-Freon

EFFECTIVE CAPACITY(L)
1069L

ELECTRIC CONSUMPTION	Cooling	746W
	Moter	645W
	Heater	878W
COMPRESSOR	Hermetic 900W	
REFRIGERANT	HFC R404A 550g	
DEFROST SYSTEM	Heater	
ACCESSORIES	SHELF	6 pcs
	BOTTOM SHELF	2 pcs
	SHELF CLIP	24 pcs
	DRAINAGE PARTS	1 set

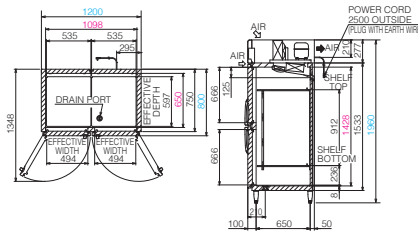

Width **1500 mm**

DLF-158AH

- OUTSIDE DIMENSIONS : W1500xD800xH1960mm
- WEIGHT : 160kg
- POWER SUPPLY : 1 Phase 220V, 50Hz



Non-Freon

EFFECTIVE CAPACITY(L)
1374L

ELECTRIC CONSUMPTION	Cooling	753W
	Moter	645W
	Heater	888W
COMPRESSOR	Hermetic 900W	
REFRIGERANT	HFC R404A 550g	
DEFROST SYSTEM	Heater	
ACCESSORIES	SHELF	6 pcs
	BOTTOM SHELF	2 pcs
	SHELF CLIP	24 pcs
	DRAINAGE PARTS	1 set

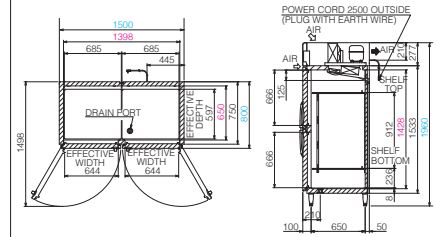

DLF-126AH

- OUTSIDE DIMENSIONS : W1200xD650xH1960mm
- WEIGHT : 130kg
- POWER SUPPLY : 1 Phase 220V, 50Hz



Non-Freon

EFFECTIVE CAPACITY(L)
831L

ELECTRIC CONSUMPTION	Cooling	746W
	Moter	645W
	Heater	878W
COMPRESSOR	Hermetic 900W	
REFRIGERANT	HFC R404A 550g	
DEFROST SYSTEM	Heater	
ACCESSORIES	SHELF	6 pcs
	BOTTOM SHELF	2 pcs
	SHELF CLIP	24 pcs
	DRAINAGE PARTS	1 set

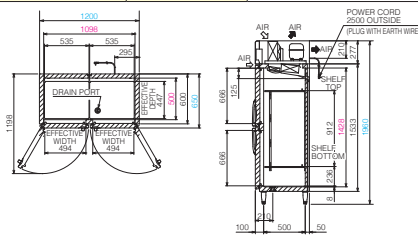

DLF-156AH

- OUTSIDE DIMENSIONS : W1500xD650xH1960mm
- WEIGHT : 150kg
- POWER SUPPLY : 1 Phase 220V, 50Hz



Non-Freon

EFFECTIVE CAPACITY(L)
1066L

ELECTRIC CONSUMPTION	Cooling	753W
	Moter	645W
	Heater	888W
COMPRESSOR	Hermetic 900W	
REFRIGERANT	HFC R404A 550g	
DEFROST SYSTEM	Heater	
ACCESSORIES	SHELF	6 pcs
	BOTTOM SHELF	2 pcs
	SHELF CLIP	24 pcs
	DRAINAGE PARTS	1 set

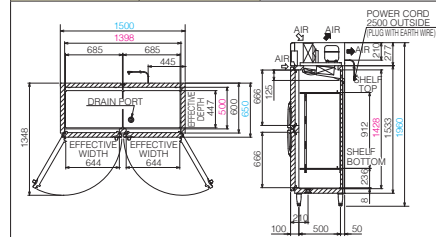

Depth **800 mm**

Depth **650 mm**



Width **1800** mm

DLF-188AH

- OUTSIDE DIMENSIONS : W1800xD800xH1960mm
- WEIGHT : 188kg
- POWER SUPPLY : 1 Phase 220V, 50Hz



EFFECTIVE CAPACITY(L)
1668L

ELECTRIC CONSUMPTION	Cooling	797W
	Moter	645W
	Heater	930W
COMPRESSOR	Hermetic 900W	
REFRIGERANT	HFC R404A 550g	
DEFROST SYSTEM	Heater	
ACCESSORIES	SHELF	9 pcs
	BOTTOM SHELF	3 pcs
	SHELF CLIP	36 pcs
	DRAINAGE PARTS	1 set

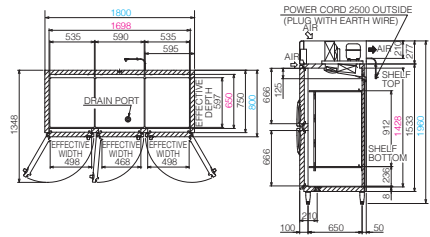

Depth **800** mm

DLF-186AH

- OUTSIDE DIMENSIONS : W1800xD650xH1960mm
- WEIGHT : 175kg
- POWER SUPPLY : 1 Phase 220V, 50Hz



EFFECTIVE CAPACITY(L)
1297L

ELECTRIC CONSUMPTION	Cooling	797W
	Moter	645W
	Heater	930W
COMPRESSOR	Hermetic 900W	
REFRIGERANT	HFC R404A 550g	
DEFROST SYSTEM	Heater	
ACCESSORIES	SHELF	9 pcs
	BOTTOM SHELF	3 pcs
	SHELF CLIP	36 pcs
	DRAINAGE PARTS	1 set

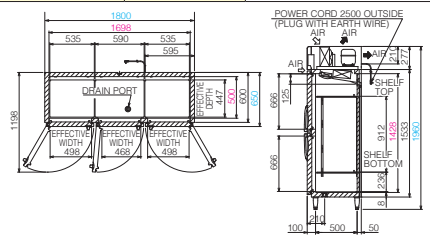

Depth **650** mm

Special orders to fulfill the customer needs

Pass through refrigerator

Pass-through refrigerator will bring a high quality hygiene control management. It prevents cross-contamination by dividing work sections.

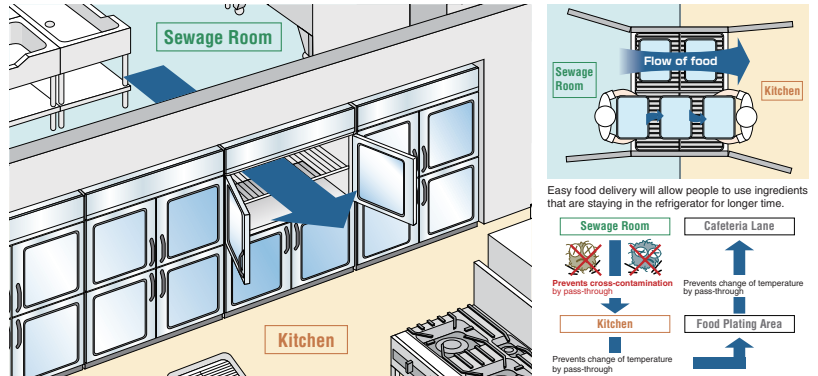

Upright type Refrigerator / Freezer



Installation Example

Our products keep reliability and safety for food at school kitchens and food factory where strict hygiene management are needed.



Center non-pillar

Large Plates or Containers Can Be Fit In. Large Storage Space Let You Work Smoothly!

Build to Load Large Capacity

90kg can be supported for the 90mm-width rack, 120kg can be supported for the 1200mm-width rack, and 150kg can be supported for 1500mm-width rack.

Large Plates, Containers Can Be Fit

No Center Pillar Enables You to Put Large Things

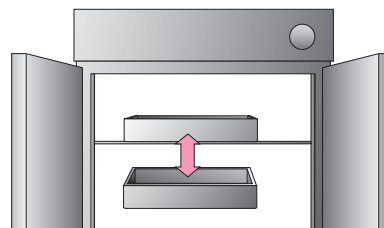

Improved Workability

No Wasted Space Inside

Available to Open by left or right

Easy to Organize Inside

Heavy Things Can be Safely Stored

With Center Pillar

It's hard to work, large plates and containers cannot be put in

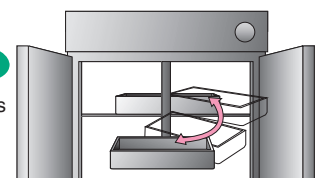

Undercounter

Easy to Use

Functionality and reliability are fully equipped on the refrigerator and freezer. Easy to use undercounter.



Micro-computer Controlled & Digital Display

Adapted Micro-computer control method that can set the temperature in 1°C increments depending on food items.



Passed 300,000 Times Open / Close Test

Strengthen the door by installing stainless hinges to endure frequent open / close movements.

Automatic Door Closer with a Stopper

You don't have to worry about closing the door as doors are automatically closed. It will prevent inside temperature to go up.



Top Table -Easy to Drain

The curved top table makes it easy to drain water. It prevents stains of door gasket.

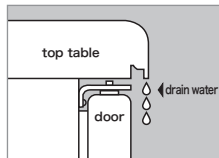

High thermal insulation performance door-back / Gasket

with improved door-back and gasket enhance thermal insulation.



LED Lights Installed (refrigerators only)

Lighting of LED makes it easy to put food in and out.



Easy Maintenance

Designed to easily clean or maintain the machine.

Clear Coat Stainless steel.

Clear Coat Stainless steel is used on the doors and the front cover. Better water-repellency, oil-repellency allows you to clean stains from foods, fingerprints on the surface easily.



Improved materials will make it even easier to keep your kitchen clean.

Curved Edges Inside

Edges and corners are curved. Therefore it is easy to clean the edges.



Swing Panel

Swing panel is installed, so that you don't have to take off the front panel when you clean or at the time of maintenance. Easy to open / close with one hand.



Large Drain Trap

A larger hose prevents clogging and makes it easy to clean. It also prevents bugs to come inside or leakage of cool air or odors.



Easy-grip Handles

Handles are designed for an easy gripping for open and close the door with a delicate design.



Easy to replace gasket

Easy to install due to the inlay type.



Easy removable air filter at the front

Air filter that protect condensers from dust is located at the front. Easy to take out and wash.



*Please clean it twice a month for a smooth running

Machine Unit in a Drawer

You can pull the machine unit when you open the swing panel.



Refrigerant Gas Filling Port Installed

Convenient for checking the volume of refrigerant gas or filling when it is needed, The port is also useful when collecting the gas.



Attentive design, safety for customers

We checked detail functionality to enhance the ability of table.

Resin Legs

Prevent stains and rust. Easy to adjust the high (40mm maximum adjustable)



Adjustable Rack

The rack is adjustable by every 12mm. You can change the layout of shelves for various use.



220 Power Plug Installed

Solutions to any power matters. Prevents accidents to insert mistakes.



Adjustable Leg (option)

An adjustable legs enables its height to adjust up to 850mm.



Earth Leakage Breaker

Earth leakage breaker is equipped to strengthen the safety of customers.



Made to order

Examples of special orders to create the ideal kitchen. Please inquire us to bring your dream kitchen to reality.

Refrigerator Drawers & Table

To operate kitchen better, we can accommodate dividing small sections. Easily design food management system to make it easy for restaurants with many part-time workers.

Various Layout for Hotel Pans



Sandwich table



Extended - table Model

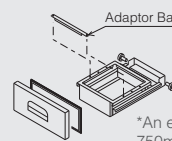

*An example of 750mm-length type

Improves food management, kitchen operation. Divided into small drawers contributes kitchen sanitation.

Optional Parts

Optional parts to fulfill needs of each kitchen environment. Please inquire us for delivery date and prices of optional parts as some of them are made to order.

Drainage Automatic Evaporate Unit (made to order)

Water from defrosting will be stored on an evaporation plate and automatically evaporated. Plumbing work is not necessary. The unit is very useful for the place with no sewage system or difficult to do plumbing work.

Please extend adjustable legs to over 100mm. Change adjustable legs when you cannot extend them over 100mm.

*Please extend adjustable legs to over 100mm. Change adjustable legs when you cannot extend them over 100mm.

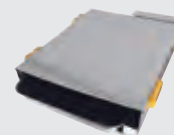

Model	Size (mm)			Power	Ability to Evaporate (cc/hour)
	Width	Length	Height		
JU220V	320	450	95	220V 1 φ 145W	120

Width **880 mm**

Width **1200 mm**

Width **1500 mm**

DKR-096AH

- OUTSIDE DIMENSIONS : W880xD600xH800mm
- WEIGHT : 57kg
- POWER SUPPLY : 1 Phase 220V, 50Hz

Non-Freon
LED



EFFECTIVE CAPACITY(L)
153L

ELECTRIC CONSUMPTION	Cooling	185W
	Motor	175W
	Heater	193W
COMPRESSOR	Hermetic 200W	
REFRIGERANT	HFC R134a 95g	
DEFROST SYSTEM	Glass Tube Heater	
ACCESSORIES	SHELF	2 pcs
	SHELF CLIP	8 pcs
	DRAINAGE PARTS	1 set

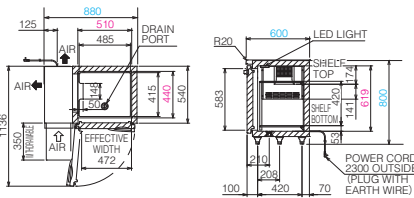

DKR-126AH

- OUTSIDE DIMENSIONS : W1200xD600xH800mm
- WEIGHT : 69kg
- POWER SUPPLY : 1 Phase 220V, 50Hz

Non-Freon
LED



EFFECTIVE CAPACITY(L)
246L

ELECTRIC CONSUMPTION	Cooling	195W
	Motor	175W
	Heater	203W
COMPRESSOR	Hermetic 200W	
REFRIGERANT	HFC R134a 95g	
DEFROST SYSTEM	Glass Tube Heater	
ACCESSORIES	SHELF	4 pcs
	SHELF CLIP	16 pcs
	DRAINAGE PARTS	1 set

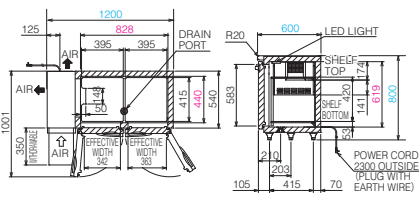

DKR-156AH

- OUTSIDE DIMENSIONS : W1500xD600xH800mm
- WEIGHT : 78kg
- POWER SUPPLY : 1 Phase 220V, 50Hz

Non-Freon
LED



EFFECTIVE CAPACITY(L)
337L

ELECTRIC CONSUMPTION	Cooling	198W
	Motor	175W
	Heater	206W
COMPRESSOR	Hermetic 200W	
REFRIGERANT	HFC R134a 95g	
DEFROST SYSTEM	Glass Tube Heater	
ACCESSORIES	SHELF	4 pcs
	SHELF CLIP	16 pcs
	DRAINAGE PARTS	1 set

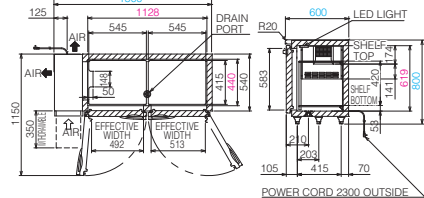

DKR-097AH

- OUTSIDE DIMENSIONS : W880xD750xH800mm
- WEIGHT : 62kg
- POWER SUPPLY : 1 Phase 220V, 50Hz

Non-Freon
LED



EFFECTIVE CAPACITY(L)
201L

ELECTRIC CONSUMPTION	Cooling	185W
	Motor	175W
	Heater	193W
COMPRESSOR	Hermetic 200W	
REFRIGERANT	HFC R134a 95g	
DEFROST SYSTEM	Glass Tube Heater	
ACCESSORIES	SHELF	2 pcs
	SHELF CLIP	8 pcs
	DRAINAGE PARTS	1 set

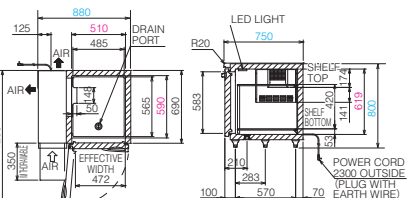

DKR-127AH

- OUTSIDE DIMENSIONS : W1200xD750xH800mm
- WEIGHT : 80kg
- POWER SUPPLY : 1 Phase 220V, 50Hz

Non-Freon
LED



EFFECTIVE CAPACITY(L)
325L

ELECTRIC CONSUMPTION	Cooling	195W
	Motor	175W
	Heater	203W
COMPRESSOR	Hermetic 200W	
REFRIGERANT	HFC R134a 95g	
DEFROST SYSTEM	Glass Tube Heater	
ACCESSORIES	SHELF	4 pcs
	SHELF CLIP	16 pcs
	DRAINAGE PARTS	1 set

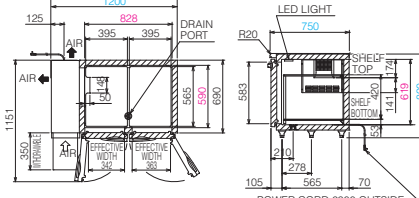

DKR-157AH

- OUTSIDE DIMENSIONS : W1500xD750xH800mm
- WEIGHT : 86kg
- POWER SUPPLY : 1 Phase 220V, 50Hz

Non-Freon
LED



EFFECTIVE CAPACITY(L)
444L

ELECTRIC CONSUMPTION	Cooling	198W
	Motor	175W
	Heater	206W
COMPRESSOR	Hermetic 200W	
REFRIGERANT	HFC R134a 95g	
DEFROST SYSTEM	Glass Tube Heater	
ACCESSORIES	SHELF	4 pcs
	SHELF CLIP	16 pcs
	DRAINAGE PARTS	1 set

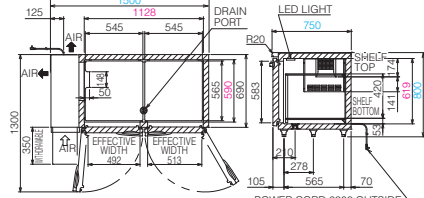

Depth **600 mm**

Depth **750 mm**

Refrigerator

Refrigerating compartment :
-6°C to 12°C

Freezer

Freezing compartment : -25°C to -7°C



Under counter

Width **1800 mm**

Width **880 mm**

Width **1200 mm**

DKR-186AH

- OUTSIDE DIMENSIONS : W1800xD600xH800mm
- WEIGHT : 90kg
- POWER SUPPLY : 1 Phase 220V, 50Hz



- Non-Freon
- LED
- clear
- Stainless
- MC & DT
- HFC

EFFECTIVE CAPACITY(L)
426L

ELECTRIC CONSUMPTION	Cooling	208W
	Motor	175W
	Heater	216W
COMPRESSOR	Hermetic 200W	
REFRIGERANT	HFC R134a 95g	
DEFROST SYSTEM	Glass Tube Heater	
ACCESSORIES	SHELF	6 pcs
	SHELF CLIP	24 pcs
	DRAINAGE PARTS	1 set

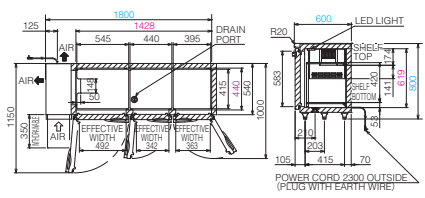

DKF-096AH

- OUTSIDE DIMENSIONS : W880xD600xH800mm
- WEIGHT : 61kg
- POWER SUPPLY : 1 Phase 220V, 50Hz



EFFECTIVE CAPACITY(L)
153L

ELECTRIC CONSUMPTION	Cooling	367W
	Motor	345W
	Heater	205W
COMPRESSOR	Hermetic 500W	
REFRIGERANT	HFC R404A 155g	
DEFROST SYSTEM	Glass Tube Heater	
ACCESSORIES	SHELF	2 pcs
	SHELF CLIP	8 pcs
	DRAINAGE PARTS	1 set

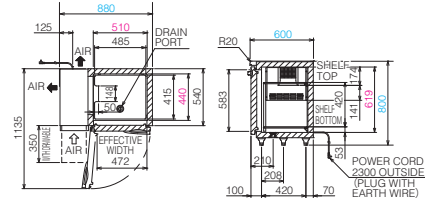

DKF-126AH

- OUTSIDE DIMENSIONS : W1200xD600xH800mm
- WEIGHT : 73kg
- POWER SUPPLY : 1 Phase 220V, 50Hz



EFFECTIVE CAPACITY(L)
246L

ELECTRIC CONSUMPTION	Cooling	382W
	Motor	345W
	Heater	220W
COMPRESSOR	Hermetic 500W	
REFRIGERANT	HFC R404A 155g	
DEFROST SYSTEM	Glass Tube Heater	
ACCESSORIES	SHELF	4 pcs
	SHELF CLIP	16 pcs
	DRAINAGE PARTS	1 set

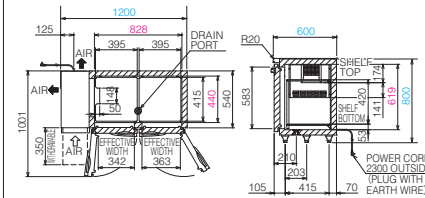

DKR-187AH

- OUTSIDE DIMENSIONS : W1800xD750xH800mm
- WEIGHT : 102kg
- POWER SUPPLY : 1 Phase 220V, 50Hz



- Non-Freon
- LED
- clear
- Stainless
- MC & DT
- HFC

EFFECTIVE CAPACITY(L)
561L

ELECTRIC CONSUMPTION	Cooling	208W
	Motor	175W
	Heater	216W
COMPRESSOR	Hermetic 200W	
REFRIGERANT	HFC R134a 95g	
DEFROST SYSTEM	Glass Tube Heater	
ACCESSORIES	SHELF	6 pcs
	SHELF CLIP	24 pcs
	DRAINAGE PARTS	1 set

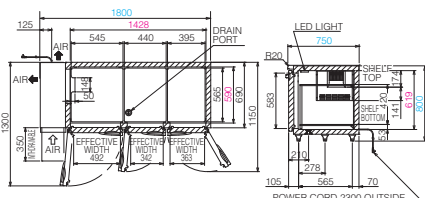

DKF-097AH

- OUTSIDE DIMENSIONS : W880xD750xH800mm
- WEIGHT : 66kg
- POWER SUPPLY : 1 Phase 220V, 50Hz



EFFECTIVE CAPACITY(L)
201L

ELECTRIC CONSUMPTION	Cooling	367W
	Motor	345W
	Heater	205W
COMPRESSOR	Hermetic 500W	
REFRIGERANT	HFC R404A 155g	
DEFROST SYSTEM	Glass Tube Heater	
ACCESSORIES	SHELF	2 pcs
	SHELF CLIP	8 pcs
	DRAINAGE PARTS	1 set

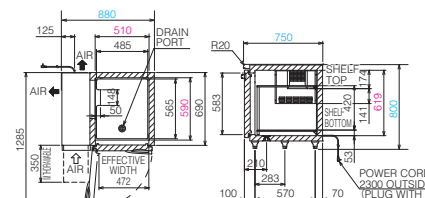

DKF-127AH

- OUTSIDE DIMENSIONS : W1200xD750xH800mm
- WEIGHT : 84kg
- POWER SUPPLY : 1 Phase 220V, 50Hz



EFFECTIVE CAPACITY(L)
325L

ELECTRIC CONSUMPTION	Cooling	382W
	Motor	345W
	Heater	220W
COMPRESSOR	Hermetic 500W	
REFRIGERANT	HFC R404A 155g	
DEFROST SYSTEM	Glass Tube Heater	
ACCESSORIES	SHELF	4 pcs
	SHELF CLIP	16 pcs
	DRAINAGE PARTS	1 set

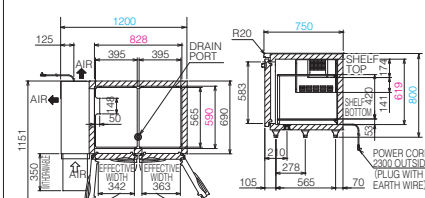

Depth **600 mm**

Depth **750 mm**

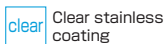
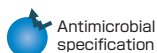

Width **1500** mm

Width **1800** mm

DKF-156AH

- OUTSIDE DIMENSIONS : W1500xD600xH800mm
- WEIGHT : 82kg
- POWER SUPPLY : 1 Phase 220V, 50Hz

Non-Freon



EFFECTIVE CAPACITY(L)
337L

ELECTRIC CONSUMPTION	Cooling	384W
	Motor	345W
	Heater	222W
COMPRESSOR	Hermetic 500W	
REFRIGERANT	HFC R404A 155g	
DEFROST SYSTEM	Glass Tube Heater	
ACCESSORIES	SHELF	4 pcs
	SHELF CLIP	16 pcs
	DRAINAGE PARTS	1 set

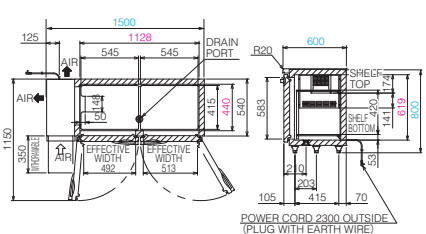

DKF-186AH

- OUTSIDE DIMENSIONS : W1800xD600xH800mm
- WEIGHT : 94kg
- POWER SUPPLY : 1 Phase 220V, 50Hz

Non-Freon



EFFECTIVE CAPACITY(L)
426L

ELECTRIC CONSUMPTION	Cooling	398W
	Motor	345W
	Heater	236W
COMPRESSOR	Hermetic 500W	
REFRIGERANT	HFC R404A 155g	
DEFROST SYSTEM	Glass Tube Heater	
ACCESSORIES	SHELF	6 pcs
	SHELF CLIP	24 pcs
	DRAINAGE PARTS	1 set

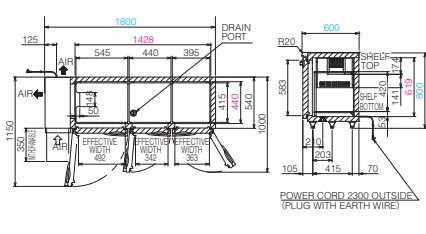

DKF-157AH

- OUTSIDE DIMENSIONS : W1500xD750xH800mm
- WEIGHT : 90kg
- POWER SUPPLY : 1 Phase 220V, 50Hz

Non-Freon



EFFECTIVE CAPACITY(L)
444L

ELECTRIC CONSUMPTION	Cooling	384W
	Motor	345W
	Heater	222W
COMPRESSOR	Hermetic 500W	
REFRIGERANT	HFC R404A 155g	
DEFROST SYSTEM	Glass Tube Heater	
ACCESSORIES	SHELF	4 pcs
	SHELF CLIP	16 pcs
	DRAINAGE PARTS	1 set

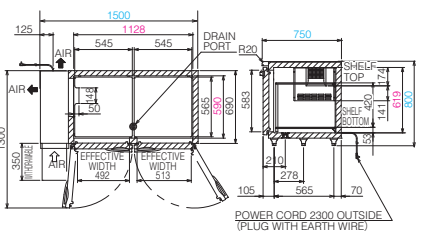

DKF-187AH

- OUTSIDE DIMENSIONS : W1800xD750xH800mm
- WEIGHT : 106kg
- POWER SUPPLY : 1 Phase 220V, 50Hz

Non-Freon



EFFECTIVE CAPACITY(L)
561L

ELECTRIC CONSUMPTION	Cooling	398W
	Motor	345W
	Heater	236W
COMPRESSOR	Hermetic 500W	
REFRIGERANT	HFC R404A 155g	
DEFROST SYSTEM	Glass Tube Heater	
ACCESSORIES	SHELF	6 pcs
	SHELF CLIP	24 pcs
	DRAINAGE PARTS	1 set

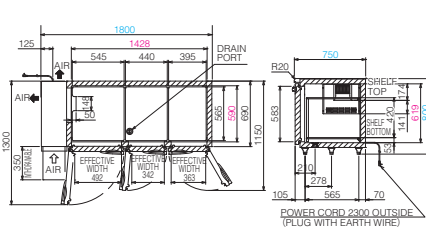

Special orders to fulfill the customer needs

Pass through refrigerator

Pass-through refrigerator will bring a high quality hygiene control management. It prevents cross-contamination by dividing work sections.

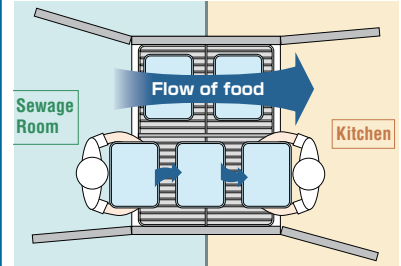

Easy food delivery will allow people to use ingredients that are staying in the refrigerator for longer time.

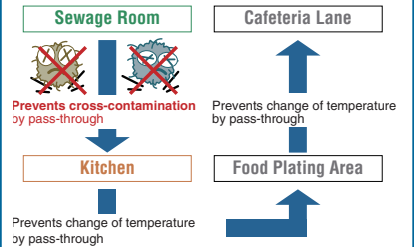

Undercounter type



Center non-pillar

Large Plates or Containers Can Be Fit In. Large Storage Space Let You Work Smoothly!

Large Plates, Containers Can Be Fit

No Center Pillar Enables You to Put Large Things

Improved Workability

No Wasted Space Inside

Available to Open by left or right

Easy to Organize Inside

Depth **600** mm

Depth **750** mm

Countershowcase (100V only)



Constant temperature and high humidity chamber type

3°C - 10°C temperature adjustable (ambient temperature: 10-30°C)/humidity 80% [ambient temperature should be: 25°C]
Tests conducted under our company regulations

Double Glazed

Humidity **80%**

“Show the Freshness”, No food wrap necessary, keeps products fresh.

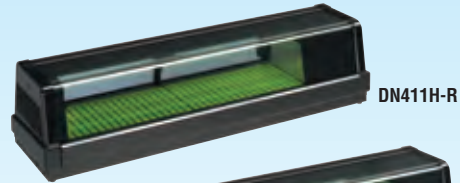

DN411H-R

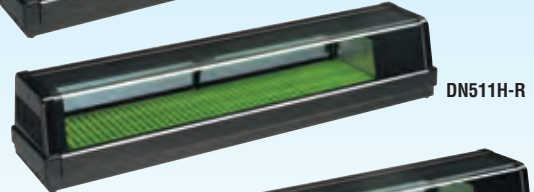

DN511H-R

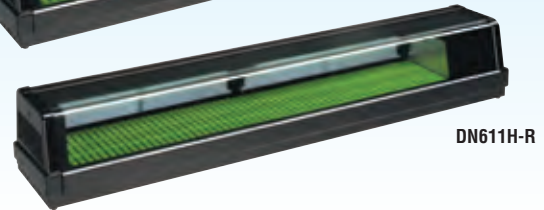

DN611H-R

Double glazing prevents condensation with an air layer

Double glazing with an air layer

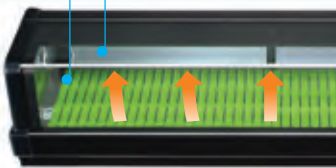

Double glazing used for the showcase. Warm air comes out of the bottom part of the front glass to prevent condensation.

Temperature Adjuster Installed

You don't need to adjust the temperature inside the showcase as you open / close it. The temperature is stabilized by the temperature adjuster.

A large front glass allows customers to see the displayed items clearly.

129mm high



The wide-opened showcase allows customers to see items inside clearly. 129mm high of machine compartment made it possible.

MODEL	OUTSIDE DIMENSIONS(mm)			EFFECTIVE CAPACITY
	Width	Depth	Height	
DN411H-R(L)	1200	343	328	37L
DN511H-R(L)	1500	343	328	49L
DN611H-R(L)	1800	343	328	62L

*Please specify the position of the machine when ordering: the Right(-R) or the Left(-L).

*Please note that model "-R" indicates the machine is on the right side, and "-L" is on the left side of the refrigerator when looking from the front side.

Shinsen-kun

Showcase temperature: 10°C or lower *This product doesn't come with a temperature adjuster in the refrigerator.

Brighten the Items Inside. The Quiet and Beautiful Showcase is Here.

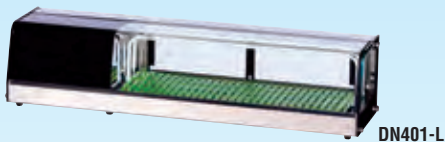

DN401-L



DN401-R

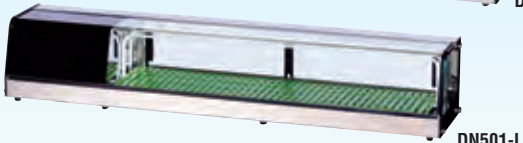

DN501-L



DN501-R



DN601-L

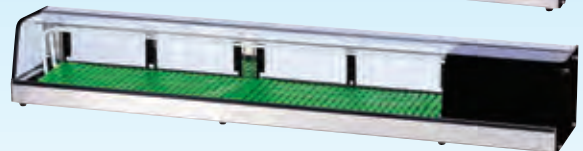

DN601-R

MODEL	OUTSIDE DIMENSIONS(mm)			EFFECTIVE CAPACITY
	Width	Depth	Height	
DN401-R(L)	1,200 (1,220)	290	275	31L
DN501-R(L)	1,500 (1,520)	290	275	43L
DN601-R(L)	1,800 (1,820)	290	275	55L

*Please specify the position of the machine when ordering: the Right(-R) or the Left(-L).

*Please note that model "-R" indicates the machine is on the right side, and "-L" is on the left side of the refrigerator when looking from the front side.

Option We have drain board as an option to prevent your products to get too cold when outside temperature is low.

Beautifully Designed Exterior

Top and front part of the showcase has no seam, and the connection between the machine area and showcase is smoothly designed. Jet black color provides luxurious feeling to it.

Easy to clean the filter



The slide filter allows you to clean it easily.

Drain Pan for cleaning condenser



There is a drain pan installed to clean the condenser (connect a hose to the pan when cleaning).
*Please do not wash on the counter. Set the surroundings to prevent damages before you conduct.

Widen the viewing angle

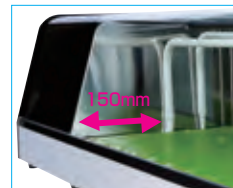

Ceiling coil has been placed in the back to widen the space inside. Drain board can be placed with an angle for customers to see items better.

Drains Easily



The display area has an angle for customers to see the items better, and the bottom of the chamber has an angle backwards for easy drainage.

*Counter showcases are for temporary use only, please clean, defrost and turn it off after the business hours every day. Please place displayed items back to refrigerator to store for the night.

Produced on Order

Please inquire us for details and delivery date.



Reduces the electricity cost by 59%, improved design. The first inverter controlled showcase for 2400mm-width model.

Ecozo-kun



TCR803-EC

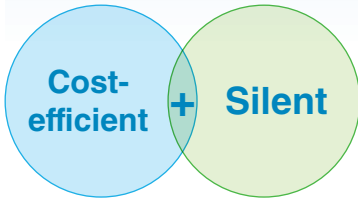

Inverter controlled compressor, condensation fan, showcase fan and DC power supply system installed for Defrost fan. LED lights used as standard feature for bulbs to last longer with less energy. High thermal insulation vacuum glass and airtight resin frame used for the sliding doors. With these materials, we are able to provide cost-efficient, silent high humidity showcase.

As of February 2013. Food Showcases in Japan (An internal investigation)

New Design

● Easy to See

The area of the front glass is wider than the previous model, now it is easy for customers to see the items in the showcase. (R-model)

● Glasses on the Sides

White gray colored glass used on the sides. Double Glazing used to prevent condensation.

● Flat Ceiling

The flat ceiling allows you to choose a panel that suits your shop.

● Front-Bottom is Trimmed

The lower part of the front-side is trimmed, so it is easy for customers to get closer to the showcase.



● Mirrored Stainless Steel

Mirrored stainless steel used as frames to give luxurious feeling to the showcase.

● LED Lights as a Standard Feature

Two lanes of LED lights are also available as an option.



Improved Features for Maintenance

Roll-slitler Installed at the Air Outlet

Easy to wipe to keep it clean. Roll-slitler installed on the back side of the air outlet.



Open / Close Fan Cover

The openable cabinet fan cover makes it easy to check and maintain.



Machine in a Drawer type machine

The machine unit is easily separated into cooling unit & control box for maintenance.



Hydrophilic, Anti-bacterial Tray Installed

You can pull out the tray at the lower part of evaporator to remove dust to keep it clean to protect bacteria from increasing.



The hydrophilic, anti-bacteria tray is easy to clean with water to prevent stains.



TCK601-EC
(Foot light, wood panel for frames are available as an option)



High Transparency Glass Installed Front-defrost

Standard Feature

A high transparency glass allows high transmittance of light at the front glass. The quality of this glass is the same as the glasses used in museums. The showcase helps you to attract customers to your items.

Air outlets are placed by the front and side glasses to prevent condensation.

*Ambient condition must be dry-bulb temperature: 27°C, relative humidity: 60%, wind speed: below 0.2m/sec when using this machine.

- EXTERIOR**
 Top plate : designated color sheet or color glass
 Front : high transparency glass
 Frames : mirrored stainless
 Waist level : pre-arranged color sheet or color glass

- INTERIOR**
 Shelf plate : glass
 Bottom plate : stainless hairline
 Sliding door : high thermal insulation vacuum glass
 Light : LED

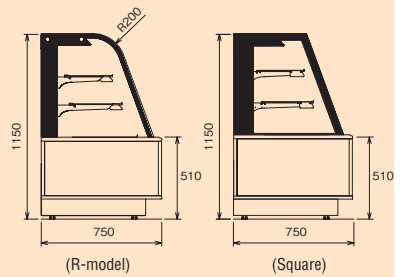

100V Inverter

Produced on Order

	MODEL	OUTSIDE DIMENSIONS(mm)		
		Width	Depth	Height
R-model	TCR401-EC	1200	750	1150
	TCR501-EC	1500		
	TCK601-EC	1800		
	TCR801-EC	2400		
Square	TCK401-EC	1200	750	1150
	TCK501-EC	1500		
	TCK601-EC	1800		
	TCK801-EC	2400		

POWER SUPPLY : 100V · 1ϕ AUXILIARY 100V · 1ϕ 50/60Hz



Made to order model to fulfill all of the needs of the customer

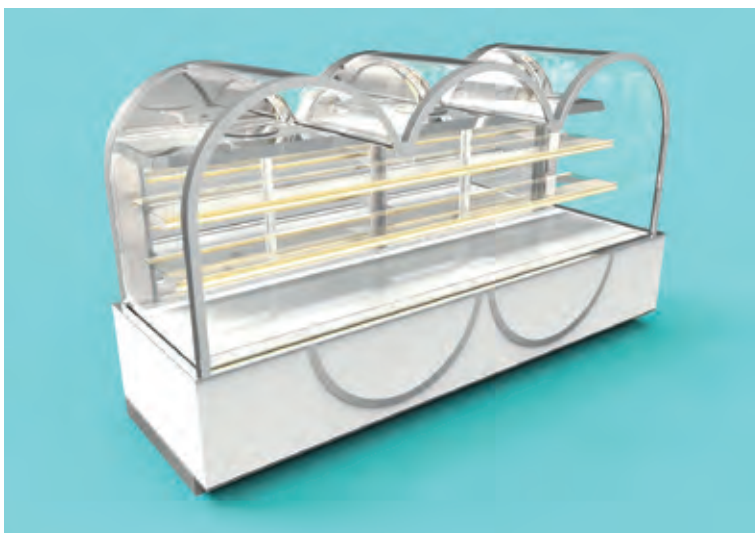

Corrugated-model



Swing Up



Flip-up-model

Produced on Order Please inquire us for details and delivery date.



Top-class energy saving rate in the industry: **78%**

Compared to our conventional model(421CD)



Inverter controlled refrigerator/Freezer **Ecozo-kun**

Cost-efficiency improved by renewed inverter compressor, condensation fan and enhanced thermal insulation performance.

Inverter Controlled Refrigerator/Freezer ECOZO-kun 421CD-EC



2016 Energy-saving Standard Achievement Rate: **138%**

Annual Electricity Consumption : **500** kWh / year

As a size of 1150mm – 1400mm class of upright refrigerator. JRAIA PR Class (As of January 2017. An internal investigation)

Triple inverter

High accuracy inverter control of the compressor and the inside fan/condenser fan. The compressor of the refrigerator-freezer is both inverter-controlled. (except some models)

■ The inverter control saving wasted electricity consumption

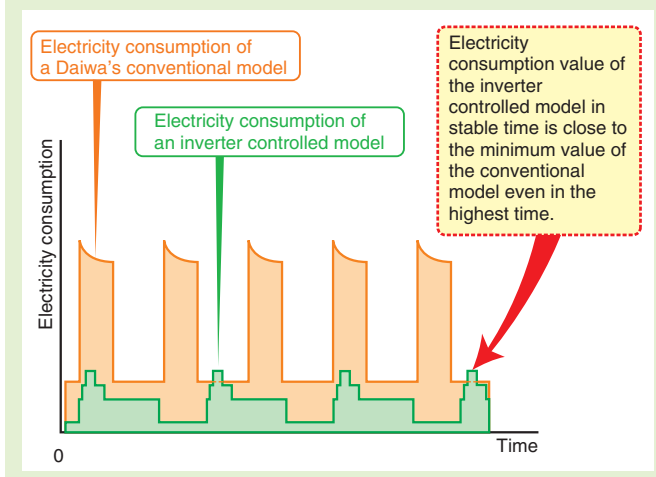

■ Reduction of annual electricity charges

The electricity cost reduced by roughly **US \$438** per year, compared to the models in the market in 2004

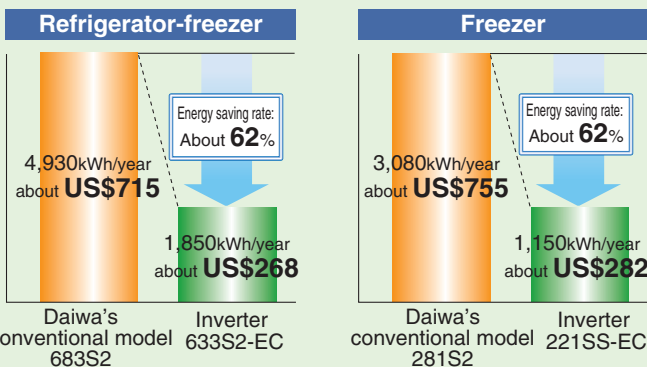
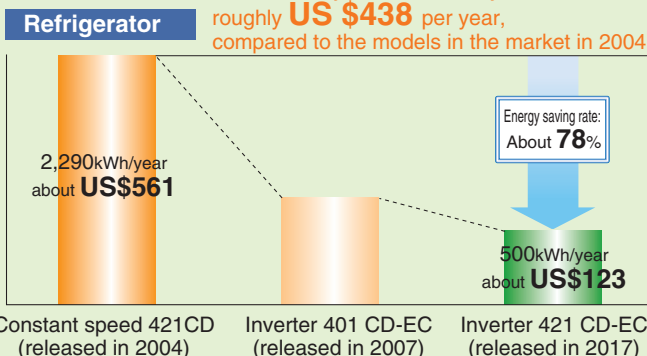

Adoption of a high temperature insulation structure BOX

A newly-developed energy saving BOX cuts off conduction of cold inside to an outside metal plate. Arranging resinous corners that prevent heat invasion in each place prevents cooling loss and enables efficient operation.

CFC-free Thermal Insulator Installed

CFC-free thermal insulator made with "cyclopentane", one of the natural refrigerants, used as a foaming agent.

JIS B 8630 [Conditions of electric energy measurement]

- Ambient temperature:-30°C, Humidity: 70%
- Temperature Inside the Refrigerator:below 4°C (open / close doors: 5min / time, open angle: 90°, 10 seconds from 2hours later after starting test to 8hours.)
- Temperature Inside the Freezer:-20° or below (open / close doors: 15min / time, open angle: 90°, 10 seconds from 2hours later after starting test to 8hours.)
- Run 24 hours •1 day electrical usage calculated to a year
- Electric fee calculated as \$0.245/kWh for 100V, and \$0.145 / kWh for 200V
- This is a comparison data with our company's products which we domestically in Japan. Convert all figures at 110 yen to a dollar.

	R245fa/ R365mf (Compared to our existing model)	Cyclopentane (ECOZO-kun)
Ozone Depletion Potential	0	0
Global Warming Potential (Case of letting CO ₂ to be 1)	890~950	3

Excellent quietness

The excellent quietness of ECOZO-kun realized comfortable kitchen environment. It is the most suitable for restaurants that set a high value on atmosphere such as open kitchen.

Daiwa's conventional model 431CD
42.7dB

Daiwa's Inverter model 421CD-EC
33.0dB



Electrical Energy Changes How You Work

You might be thinking "food loss" is the part of the management because you provide fresh products every day. Let Daiwa offers you a new way to prevent the loss. We have listed 5 points that changes business management in an efficient way by adding electrical energy into the kitchen. High quality defrosting to keep freshness for longer time. It will change the way you run business.

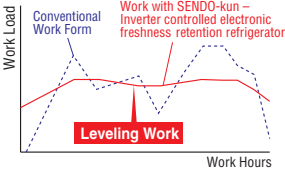

Longer lasting freshness allows you to make dishes when you have time such as between lunch and dinner hours. Sashimi may be able to cut the day before. It will also give you flexibility to adjust customers when they change plans last minutes. By being able to plan and level work in advance, it will help you to reduce utility costs and improves productivity.

Pictures: Differences after 3-days (An internal research)

Long Lasting Freshness

Tuna Sashimi

Dates counted from the day the food carried in to be Day 0.



Sendo-kun



Conventional Refrigerator



Discoloration

Differences in discoloration. It also prevents sashimi to get dried out.

Odor

There is not much odor that fresh products give off.

Dripping

Limit the dripping from products to keep the umami substance within.



Inverter
211CD-PF-EC



5861CD-PF-1

Electronic freshness retention refrigerator Sendo-kun – high humidity type

Customer with high demand on keeping freshness of products

Marriage of "Sendo-kun" and high humidity freezer made it possible to keep freshness at a premium level.

By adding electrical energy to foods, you are able to keep products fresh without wrapping 85% humidity inside the refrigerator. Change of temperature that causes food quality degradation is always monitored. It stabilizes the temperature changes within $\pm 0.5^{\circ}\text{C}$ (when doors are not opened and closed) to manage the food quality. Newly invented "6- side wall cooling system" allows inside of the doors to release cool air. The system allows a speedy cooling system and improved temperature distribution. The "air curtain system" is used to minimize the change of temperature inside the refrigerator when doors are opened.

Advantage of "Sendo-kun"

- Adding electrical energy to food makes possible for you to stock items at the temperature zone of minus to 0°C .
- This is suitable for cooked egg or chicken meat dishes or lunch box as it keeps temperature zone in minus which will accelerate antibacterial environment. Food poisoning can be prevented. Our refrigerator prevents discoloration of foods as it prevents oxidation of food.



Advantage of High Humidity Freezer

- 85% humidity is kept. No food wrap necessary to keep items inside. Not to worry about drying out or unevenly cooled which previous refrigerators often had problem with.
- Change of temperature inside the refrigerator was the problem of quality degradation. This refrigerator stabilize the temperature within $\pm 0.5^{\circ}\text{C}$.



221HC-PF-1 high humidity type

First in the Industry*

Inverter controlled Automatic-sliding door refrigerator

Automated to easily open and close doors
that provides safe, clean kitchen.

Auto-kun



Newly Designed “Touch Sensor Handle”

You can easily open / close the door by touching the sensor.
The sensor works even if you touch with back or your finger or elbow,
so it is very hygienic.



[Touch the Sensor]

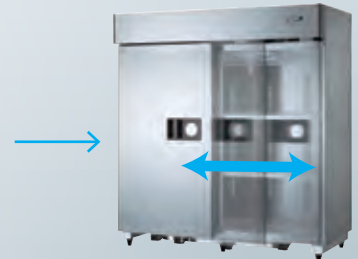

[Open / Close by Touching the Door]

Comfortable, Safe, Clean Kitchen Environment



Open / close doors even touching sensor with back of your finger or elbow. It keeps the kitchen clean as you don't have to grip the handle to open/close the doors.

Space for Your Backyard



Space that needs for this refrigerator is about half of the same type of refrigerators (comparing to 1800mm-width refrigerator). This will let you have more space in the backyard and be able to open / close doors without blocking traffics in front of the doors.

Improves Operation



You can open / close doors without having both hands open. You don't have to put things on the counter to open or close doors.

*As of January 2017. Commercial refrigerators in Japan (An internal investigation)



401CD-SA-EC



501CD-SA-EC



601CD-SA-EC

Saves spaces with sliding doors

Inverter controlled Sliding door refrigerator **Ecozo-kun**

Sliding doors that opens both sides will let take out or put in products easily without blocking the traffics in front of the refrigerator. It will allow you to place this refrigerator where you never thought it can be placed at. You will save up space as this can be fitted into a small space. "Smart open / close system" used on the rail of the door to smoothly open / close the door to improve your operation. (representative models)

Smart Open / Close System Installed



Smart Open / Close System

Open / close doors easily with one hand.

New Refrigerator

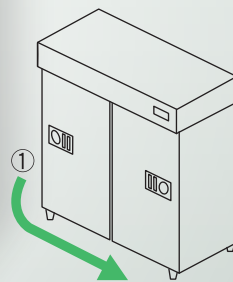

Easy to Open / Close

Conventional Refrigerator

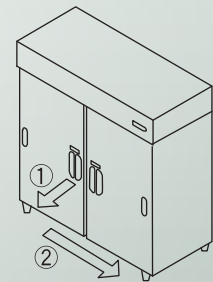

Two Steps Needed to Open

Sliding Doors that Provides More Space for Operation

Only 1/2 of space is needed for this refrigerator compared to regular commercial refrigerators.

(comparing to 1800mm-width refrigerator)

You can open / close doors at a limited space, such as backyard. You will be able to put this refrigerator where you never thought a refrigerator would fit.

Regular Doors

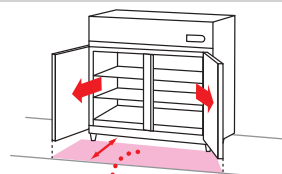

Need a Certain Space to Open / Close the Doors

Slide Doors

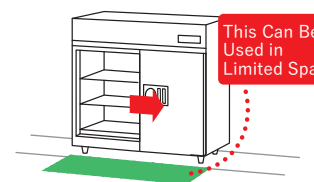

This Can Be Used in Limited Space



411CD-S-EC



521CD-S-EC



621CD-S-EC

Upright refrigerator/freezer

P.17~P.47

Depth	Width	600mm	750mm	900mm
Inverter controlled refrigerator Ecozo-kun RC : -7°C to 12°C				 Center non-pillar
	800mm	P.17 231CD-EC	P.17 231LCD-EC	P.17 331CD-EC P.18 321CD-NP-EC
	650mm	P.17 231NYCD-EC	P.17 231YCD-EC	P.17 331YCD-EC P.18 321YCD-NP-EC
Depth	Width	750mm	900mm	1200mm
Inverter controlled refrigerator-freezer Ecozo-kun RC : -7°C to 12°C FC : -25°C to -8°C				
	One Freezer	800mm P.20 211LS1-EC 650mm P.20 211YS1-EC	800mm P.20 321S1-EC 650mm P.20 321YS1-EC	800mm P.20 421S1-EC 650mm P.20 421YS1-EC
	Two Freezers	800mm P.21 311S2-EC 650mm P.21 311YS2-EC	800mm P.21 431S2-EC 650mm P.21 431YS2-EC	

Depth	Width	600mm	750mm	900mm
Inverter controlled freezer Ecozo-kun FC : -25°C to -8°C			※Depth 800mm type ※Depth 650mm type	 Center non-pillar
	800mm	P.23 221SS-EC	P.23 201LSS-EC	P.23 301SS-EC P.24 301SS-NP-EC
	650mm	P.23 221NYSS-EC	P.23 221YSS-EC	P.23 301YSS-EC P.24 301YSS-NP-EC

Depth	Width	1200mm	1500mm	1800mm
Inverter controlled sliding door refrigerator Ecozo-kun RC : -7°C to 12°C FC : -25°C to -8°C				
	860mm	P.44 401CD-SA-EC P.46 411CD-S-EC	P.44 501CD-SA-EC P.46 521CD-S-EC	P.44 601CD-SA-EC P.46 621CD-S-EC
	650mm	P.47 401YCD-S-EC		

Undercounter

P.52~P.56

Depth	Width	1200mm	1500mm	1800mm
Inverter controlled refrigerator/freezer Ecozo-kun RC : -7°C to 12°C FC : -25°C to -8°C		※refrigerator Center non-pillar	※refrigerator Center non-pillar	※refrigerator Center non-pillar
	600mm	P.52 4161CD-EC P.52 4161CD-NP-EC	P.53 5161CD-EC P.53 5161CD-NP-EC	P.53 6161CD-EC P.54 6161CD-NP-EC
	750mm	P.52 4171CD-EC	P.53 5171CD-EC	P.53 6171CD-EC
freezer	600mm	P.56 4061SS-EC P.56 4061SS-NP-EC	P.56 5061SS-EC P.56 5061SS-NP-EC	P.56 6061SS-EC P.56 6061SS-NP-EC

1200mm		1500mm		1800mm	
P.18 421CD-EC	P.18 421CD-NP-EC	P.19 521CD-EC	P.19 521CD-NP-EC	P.19 621CD-EC	
P.18 421YCD-NP-EC	P.18 423YCD-NP-EC				

1500mm			1800mm		
P.21 521S1-4-EC					
	P.22 511S2-4-EC	P.22 531S2-EC		P.22 631S2-EC	

1200mm		奥行 幅 Inverter controlled Constant temperature and high humidity chamber Ecozo-kun RC : -6°C to 12°C humidity : above 85%	750mm		1200mm	
P.24 421SS-EC	P.24 421SS-NP-EC	800mm	P.26 201HC-EC	P.26 401HC-EC	P.26 401HC-NP-EC	
P.24 421YSS-NP-EC	P.24 421YSS-NP-EC					

Depth	Width	600mm
Inverter controlled electronic freshness retention refrigerator Sendo-kun RC : -7°C to 12°C		P.30 211CD-PF-EC
800mm		

Depth	Width	650mm
Inverter controlled Low temperature storage -35°C to -20°C		P.40 201F-EC
800mm		

2100mm		Depth Width Inverter controlled refrigerator- freezer Ecozo-kun RC : -7°C to 12°C FC : -25°C to -8°C	1200mm		1500mm		1800mm		2100mm	
P.54 7161CD-EC	P.54 7161CD-NP-EC	600mm	P.55 4061S-EC	P.55 5061S-EC	P.55 6061S-EC	P.55 7061S-EC				
P.54 7171CD-EC										

RC:Refrigerating compartment
FC:Freezing compartment



Osaka Head Office

Tokyo Head Office

Osaka Head Office : Daiwareiki Uehonmachi DRK Building, 3-13 Obase-cho Tennoji-ku, Osaka Zip code: 543-0028

Tokyo Head Office : Daiwareiki Akihabara DRK Building 2-4-3 Taito Taito-ku, Tokyo Zip code: 110-0016

Saiki Factory : 3325-6 Nagara Ooaza Saiki-city, Oita Zip code: 876-1511

Fukuoka Factory : 6-32-1 Mizuki Dazaifu-city, Fukuoka Zip code: 818-0131

Kanto Otone Factory : 1-345-5 Toyono-dai Kazo-city, Saitama Zip code: 349-1148

English :
URL <http://www.daiwa-inds.com>



Japanese :
URL <http://www.drk.co.jp>



Saiki Factory is accredited for "ISO 9001:2015"



Saiki Factory



Fukuoka Factory



Kanto Otone Factory

Safety Information

Please read through "Instruction Manual" and "Installation Instruction," then use it properly.
All the products shown in this catalogue are for indoor use only. Please keep the products away from water or rain.
Please anchor refrigerators to walls or use safety devices to prevent from falling over at the time of earthquake.
Please consult with your store or specialists as some of the products may need installation, electrical, plumbing, gas fitting works.
Please do not put ether, benzene, alcohol, lighter cylinder or any other volatility or flammable items inside the refrigerator.
This refrigerator should only be used to showcase items or to keep items temporarily.
Please do not put medicine, drugs or scientific items. It may cause the refrigerators to not work properly. The refrigerator must not be used outside of its purpose.
The refrigerators are not guaranteed to use places where it swings such as inside of vehicles or boats. Please consult with your store before you start using it in such situation.
Please consult with your doctor if you have heart pacemaker (same for electromagnetic cooker).



• Please note that specs of products on this catalogue may change without prior notice for improvement purposes. • Colors of the products may look different from this printed catalogue. • Please inquire us when placing orders as models and prices may have changed from this catalogue. • The items shown inside the refrigerators in the catalogue are not included as a part of our products.



This brochure is printed by eco-friendly ink of vegetable oil